

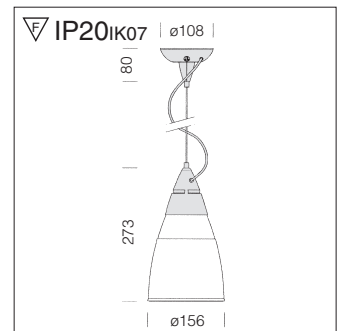

base	Watt	lamp	weight kg	colour	Code Fosnova
------	------	------	--------------	--------	-----------------

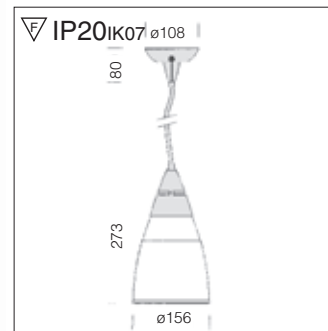

Argostar 1 suspension with wire					S
E27	max23	FLC-EL	0,90	m. silver	70072
Without coloured ring. With wire L = 1.50 m.					

Argostar 2 suspension with wire					S
E27	max23	FLC-EL	0,90	m. silver	70073
Without coloured ring. With steel wire L = 1.50 m.					

Argostar 2 suspension with wire 230V					CNL
GU10		ALU 50	0,90	m. silver	70074
Version equipped with a 230V lamp, mains voltage operated without transformer.					

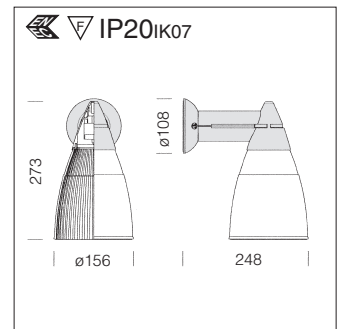
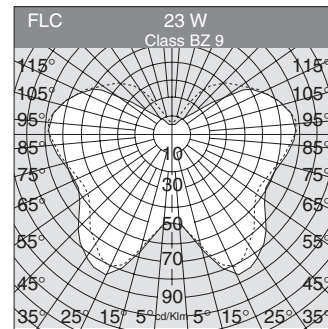
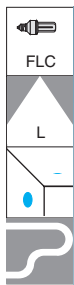

Argostar wall version					S
E27	max23	FLC-EL	1,50	m. silver	40275
Without coloured ring.					

Housing: High-temperature resistant thermoplastic material. Supplied with a sphere-opal polycarbonate cone diffuser.
Available on request chrome Argostar 2 code 70075.

Lampholder: Polycarbonate with phosphorous bronze contacts.

Electric gear: 230V-50Hz power supply 0.75 sqmm cross section 2-pole wire 2P terminal block (maximum allowed lead cross section 2.5 mm²).

Regulations: Manufactured in accordance with EN 60598-CEI 34-21 standards. Degree of protection in accordance with EN 60529 standards.



base	Watt	lamp	weight kg	colour	Code Fosnova
------	------	------	--------------	--------	-----------------

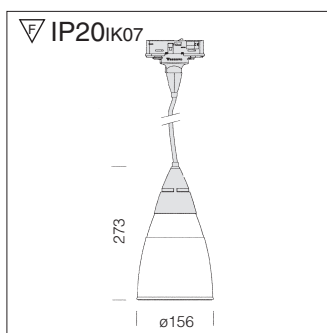
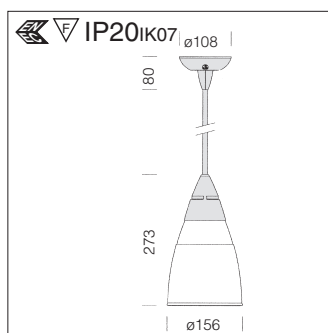

Argostar 3 with rods					S
E27	max23	FLC-EL	1,20	m. silver	70071
Without coloured ring. With rods L = 0,50 m.					

Argostar 4 suspension					S
E27	max23	FLC-EL	0,90	m. silver	70174
Without coloured ring. Wire L = 1,5 m.					



ALO	50 W	25°
1	Ø 0.44	1158
2	Ø 1.89	290
3	Ø 1.33	129
4	Ø 1.77	72
m		lux

Coloured ring	
white	91811
red	91822
green	91843
yellow	91854
blue	91885

Coloured finishing ring to be fitted to the opal cone. To be used only when the reflector is oriented downwards.

