



Recessed floodlight. A choice of different luminous sources makes it versatile and ideal for installation in any exhibition environment.

Housing: made of die-cast aluminium.

Reflector: High-efficiency polished anodised aluminium.

Diffuser: Anti-glare silk-screen printed tempered glass protection shield.

Coating: Powder-coated with a UV-resistant polyester epoxy paint.

Electric gear: 230V/50Hz power supply: Flexible wire terminated with admiralty brass clamps, silicone insulation; 2P (with plug-socket connector).

Regulations: Manufactured in accordance with EN 60598-1-CEI 34.21 standards. Degree of protection in accordance with EN60529 standards.

Lamps: Supplied with energy-saving or discharge lamps.

Metis 1 and 2 are supplied with double insulation.



base	Watt	lamp	weight kg	colour	Code ifosnova
------	------	------	--------------	--------	------------------

JM-TS
3000K
Ra=2a
5100lm

HCI-TS
3000K
Ra=2a
70W=6500lm
150W=13250lm

M

Ø 150

Ø 218

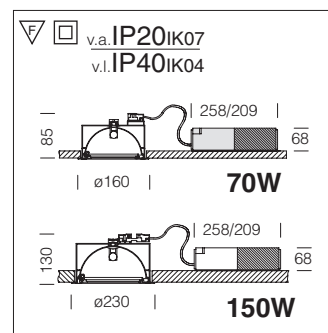
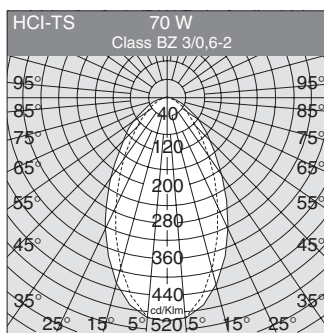

Metis 1					CNRL
RX7s	70	JM-TS	2,3	white	187510
RX7s	70	HCI-TS	2,3	white	187510-85

Complete with electric gear box and lamp.

Metis 2					CNRL
RX7s	150	JM-TS	3,3	white	187511
RX7s	150	HCI-TS	3,3	white	187511-85

Complete with electric gear box and lamp.

FLC-D
3000K
Ra=1b
1800lm

4000K
Ra=1b
1800lm

Consump.
CNRL=B2
CNRL=A2

Ø 210

M

1000

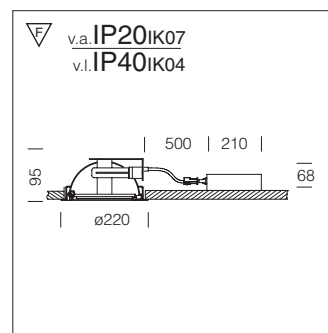
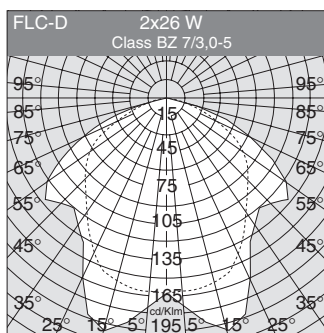

Metis 3 - 3000K					CNRL
G24d-3	2x26	FLC-D	3000K	white	187412

Metis 3 - 4000K					CNRL
G24q-3	2x26	FLC-D/E	3000K	white	187412-08

Complete with electric gear box and energy saving lamp.

Metis 3 - 4000K					CNRL
G24d-3	2x26	FLC-D	4000K	white	187411

Metis 3 - 4000K					CNRL
G24q-3	2x26	FLC-D/E	4000K	white	187411-08

Complete with electric gear box and energy saving lamp.
On request 2x13 e 2x18 versions. Electronic version is supplied with double insulation.

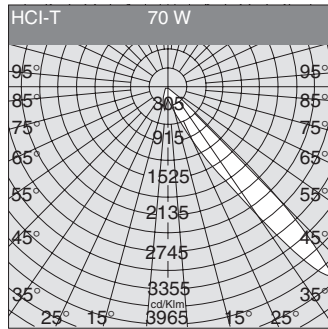
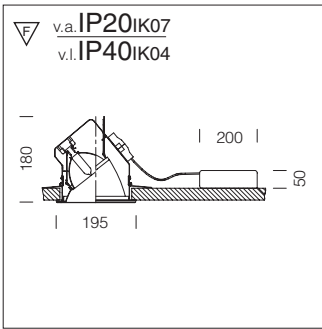

Rond 1	CELL
G24q-2 1x13 FLC-D/E 2,00 white	174011-08

Rond 2	CELL
G12 70 HCl-T 3,00 white	174016-08

Housing: steel.
Reflector: High-efficiency plated anodised and polished aluminium.

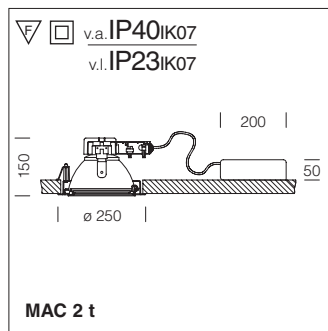
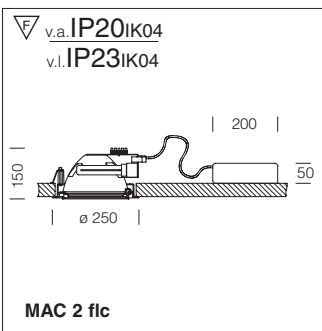

Mac 2 flc	S
R7s 200 ALO 2,30 m. silver	187671

G24q-3 2x26 FLC-D/E 4,5 white	187611-08
-------------------------------	-----------

Complete with energy saving lamp and control gear box (only for FLC-D). Ideal for installation in transit areas or in commercial zones that require all-day (energy-saving) lighting, but not high-level illumination. **fig.1**

Mac 2 t	CELL
G12 70 CDM-T 3,7 white	187711-08
G12 70 CDM-T 3,7 m. silver	187771-08
G12 150 CDM-T 4,5 white	187715-08
G12 150 CDM-T 4,5 m. silver	187775-08

Complete with electric gear box and lamp. Ideal for installation in areas requiring a high level of illumination. **fig.2**

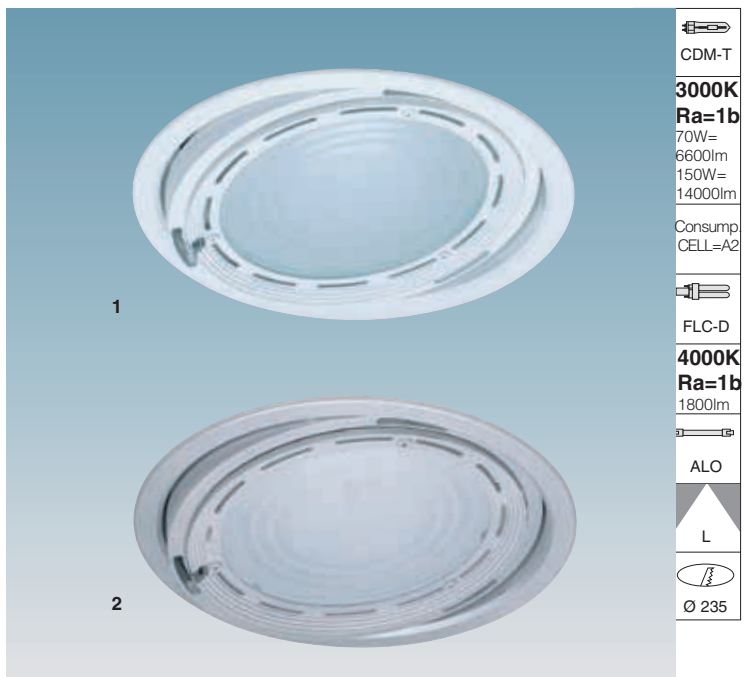

Fruit filter - Mac 2
5260
 Ideal for enhancing goods displayed in shops or fruit and vegetable departments. For CDM-T.



Fishmonger filter - Mac 2
5263
 Ideal for enhancing goods displayed in fishmonger or seafood departments. For CDM-T.

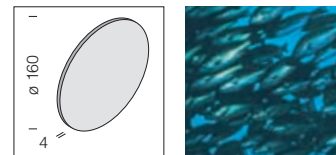

Vegetables filter - Mac 2
5261
 Ideal for enhancing goods displayed in shops or vegetable departments. For CDM-T.



Butcher's shop filter - Mac 2
5264
 Ideal for enhancing goods displayed in butcher's shops. For CDM-T.



Fabrics filter - Mac 2
5245
 Ideal for enhancing goods displayed in shops or in fabric departments. For CDM-T.

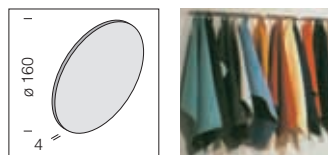

UV filter Glass - Mac 2
 Ø 160 CDM-T **5335**

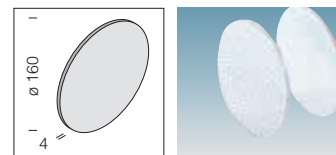

Bakery filter - Mac 2
5262
 Ideal for enhancing goods displayed in bakeries. For CDM-T.



Conveyor - Mac 2 Ømm183
 white **5320**
 black **5330**
 Made of steel. Conveys the light beam in a single direction.

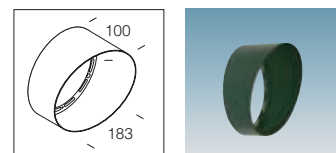

RECESSED DOWN LIGHTS