

Optical art. 3130

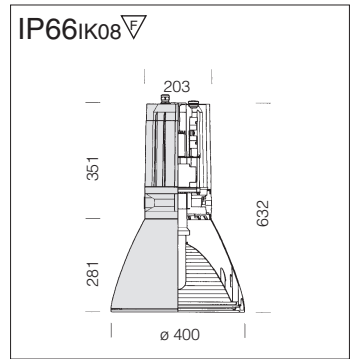

**Housing/Frame and outside reflector:** die-cast aluminium with wide cooling fins.

**Reflector:** in polished 99,85 aluminium with glass protection.

**Coating:** In several stages. First stage: grey epoxy-cationic electrocoating, resistant to corrosive and saline environments. Second stage: UV stabilising priming; final stage: rough finish with frosted acrylic paint.

**Electric gear:** 230V/50Hz power supply with heat protection. Flexible wire terminated with quick-connect admiralty brass clamps, silicone insulation with fibreglass braid, cross-section: 1 sqmm. 2P+T terminal block (maximum allowed lead cross-section: 2.5 sqmm).

**Equipment:** Rubber cable gland, Ø " " gas thread (min. cable Ø 9, max Ø12).

| 3130 Tex - narrow beam |                   |        |           |                         |
|------------------------|-------------------|--------|-----------|-------------------------|
|                        |                   | CNRL   |           | Lamps (Ta=25°C)         |
| wattage                | colour            | weight | code      | Kelvin - olm - Ra       |
| HCI-T 150              | silver + graphite | 12.30  | 326020-00 | 4200K - 14500lm - Ra 2a |
| JM-T 250               | silver + graphite | 13.20  | 326021-00 | 4000K - 20000lm - Ra 2b |
| SAP-T 150              | silver + graphite | 11.00  | 326022-00 | 2000K - 15000lm - Ra 4  |
| SAP-T 250              | silver + graphite | 11.50  | 326023-00 | 2000K - 28000lm - Ra 4  |

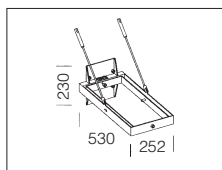

| acc. 330 single frame   |        |
|---|--------|
| s. silver   | 998062 |
| graphite  | 998063 |
| In die-cast, cationic electrocoated aluminium. For use with acc. 352. |        |

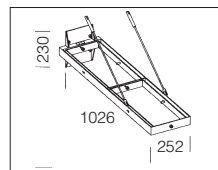

| acc. 331 double frame   |        |
|---|--------|
| s. silver   | 998064 |
| graphite  | 998065 |
| In die-cast, cationic electrocoated aluminium. For use with acc. 352. |        |

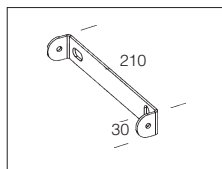

| acc. 352 bracket for frame   |        |
|--|--------|
| inox   | 998080 |
| In sheet steel. To use itself with the acc. 330 for the application to wall. |        |

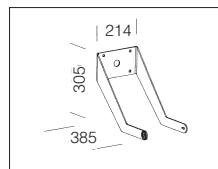

| acc. 332 bracket for frame                             |        |
|--|--------|
| s. silver  | 998066 |
| graphite   | 998067 |
| In steel sheet. For the installation to wall or earth. |        |

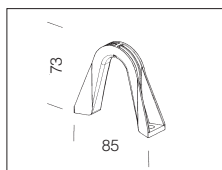

| acc. 329 suspens. connection              |        |
|---|--------|
| graphite                                  | 998061 |
| Made of aluminium. To use for suspension. |        |

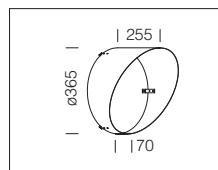

| acc. 93 conveyor   |        |
|--|--------|
| black  | 995708 |
| Used for conveying the light beam in a single direction. |        |



Bracket with adjustment protractor scale for accurate aiming of the floodlight. Supplied with fixing pin to prevent aiming variations.

Installation to wall of two fixtures with acc. 331 and bracket acc. 352.

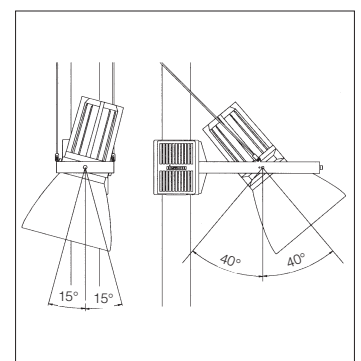

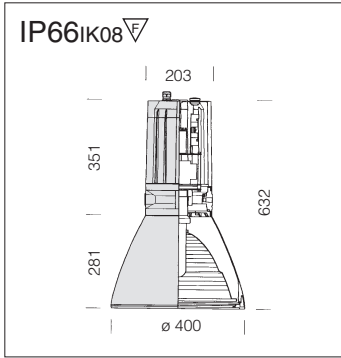

**Reflector:** in polished 99,85 aluminium with glass protection.

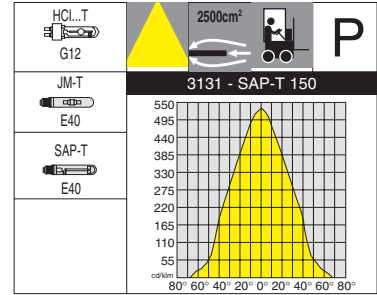

Optical art. 3131

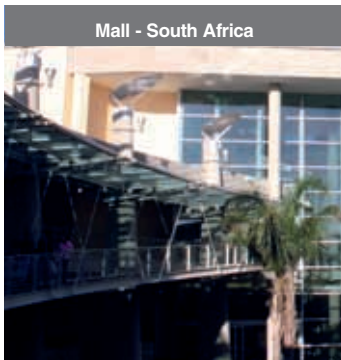

| 3131 Tex - medium beam |                   |        |           |                         |  |
|------------------------|-------------------|--------|-----------|-------------------------|--|
|                        |                   | CNRL   |           | Lamps (Ta=25°C)         |  |
| wattage                | colour            | weight | code      | Kelvin - ølm - Ra       |  |
| <b>HCI-T 150</b>       | silver + graphite | 12.30  | 326030-00 | 4200K - 14500lm - Ra 2a |  |
| <b>JM-T 250</b>        | silver + graphite | 13.20  | 326031-00 | 4000K - 19000lm - Ra 2b |  |
| <b>SAP-T 150</b>       | silver + graphite | 11.00  | 326032-00 | 2000K - 15000lm - Ra 4  |  |
| <b>SAP-T 250</b>       | silver + graphite | 11.50  | 326033-00 | 2000K - 28000lm - Ra 4  |  |

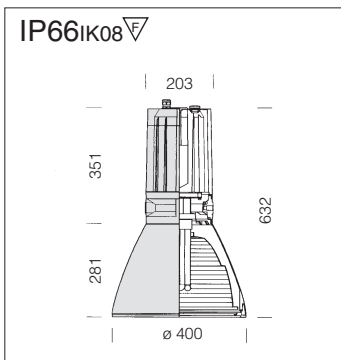

**Reflector:** in polished 99,85 aluminium with glass protection.

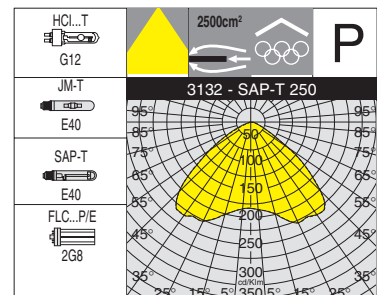

Optical art. 3132

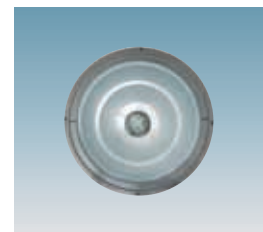

| 3132 Tex - wide beam |                   |        |           |        |           |                         |
|----------------------|-------------------|--------|-----------|--------|-----------|-------------------------|
|                      |                   | CNRL   |           | CELL   |           | Lamps (Ta=25°C)         |
| wattage              | colour            | weight | code      | weight | code      | Kelvin - ølm - Ra       |
| <b>HCI-T 150</b>     | silver + graphite | 12.30  | 326040-00 |        |           | 4200K - 14500lm - Ra 2a |
| <b>JM-T 250</b>      | silver + graphite | 13.20  | 326041-00 |        |           | 4000K - 19000lm - Ra 2b |
| <b>SAP-T 150</b>     | silver + graphite | 11.00  | 326042-00 |        |           | 2000K - 15000lm - Ra 4  |
| <b>SAP-T 250</b>     | silver + graphite | 11.50  | 326043-00 |        |           | 2000K - 28000lm - Ra 4  |
| <b>FLC 85 P/E</b>    | silver + graphite |        |           | 9.00   | 326044-00 | 4000K - 6000 lm - Ra 1b |