

Breclav Castle -Czech Republic



**Housing/frame:** Die-cast aluminium with cooling fins.

**Diffuser:** Tempered glass 5 mm thick, resistant to impact and thermal shock (UNI7142 tests, British standard 3193).

**Coating:** Graphite grey polyester powder coating, resistant to corrosive and saline environments.

**Electric gear:** 230V-50Hz power supply with heat protection. Flexible wire terminated with admiralty brass clamps, fibreglass braid insulation, cross-section: 1 sq mm (up to 400W) or 2.5 sq mm (400 to 1000W). 2P or 2P+T terminal block (maximum allowed lead cross-section 4 sqmm.)

**Equipment:** Silicone rubber gasket . Fibreglass nylon cable gland, Ø1/2 gas. Retained steel screws with special anticorrosion and anti-gripping treatment. Steel bracket with protractor scale. The hinged front frame stays attached to the housing for easy maintenance. The double insulation version is supplied with a separate gear box attached to the bracket.

Technical specifications for the 1129 JM-TS 400 spotlight:

- Beam spread: 50° ASYMM.
- Area: 2400cm<sup>2</sup>
- Light source: JM-T E40, SAP-T E40
- Beam spread diagram showing intensity distribution from -120° to 120°.

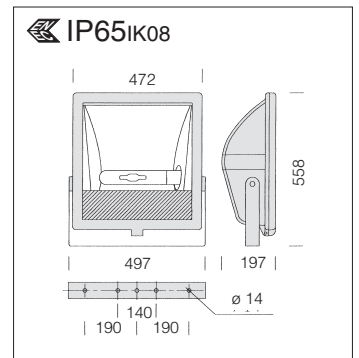

**Reflector:** asymmetric, 99.85 3µ thick anodised and polished hammered aluminium.

1129 Cromo - asymmetric								
		CNRL		CNRL double insulation		CNRL with switching device		Lamps (Ta=25°C)
wattage	colour	weight	code	weight	code	weight	code	Kelvin - ølm - Ra
SAP-T 250	graphite	16.10	412947-00	16.10	412947-14	16.10	412947-79	2000K - 28000lm - Ra 4
SAP-T 400	graphite	17.50	412948-00	17.50	412948-14	17.50	412948-79	2000K - 48000lm - Ra 4
JM-T 250	graphite	15.20	412949-00	15.20	412949-14	15.20	412949-79	4500K - 20500lm - Ra 2b
JM-T 400	graphite	16.00	412950-00	16.00	412950-14	16.00	412950-79	450 K - 35000lm - Ra 2b

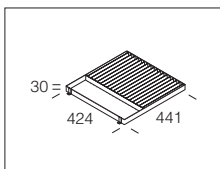

**acc. 21 baffle louvre**  
 black 995721  
 Made of steel. To reduce glare and improve light control.

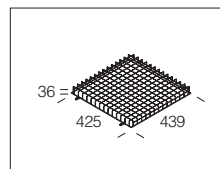

**acc. 23 protection guard**  
 black 995722  
 Plastic-coated steel rod. For protection against impact.

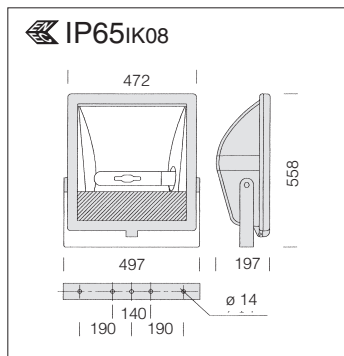

**Reflector:** asymmetric, 99.85  $\mu$ m thick anodised and polished hammered aluminium.

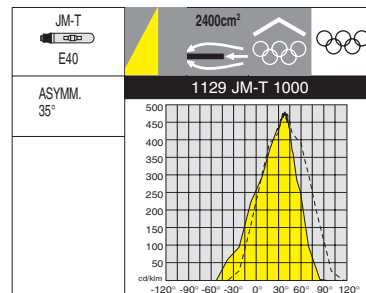

1129 Cromo - asymmetric				
		S+L		Lamps (Ta=25°C)
wattage	colour	weight	code	Kelvin - $\phi$ lm - Ra
JM-T 1000	graphite	12.50	412951-00	4400K - 90000lm - Ra 1b
To be used with acc. 1177 control gear box. If the box is placed at a distance of over 3 meters from the fixture, to buy acc. 1178 cod 997650				

acc. 1177 gear CC - IP657			
JM-T 1000	black	13.60	997643-00
Die-cast aluminium box, painted black by epoxy cationic electro-coating colour black. Recommended installation at a maximum distance of 3 meters from the fixture. Contents: ballast, igniter and capacitor.			

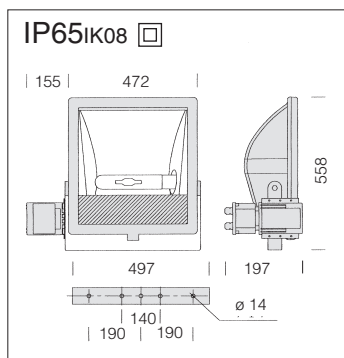

**Reflector:** asymmetric, 99.85  $\mu$ m thick anodised and polished hammered aluminium.

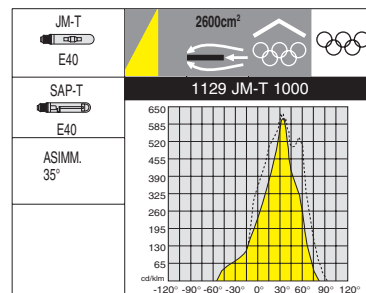

1129 Cromo - double insulation				
		CNRL		Lamps (Ta=25°C)
wattage	colour	weight	code	Kelvin - $\phi$ lm - Ra
SAP-T 600	graphite	20.00	412924-00	4400K - 90000lm - Ra 1b
JM-T 1000	graphite	20.00	412925-00	2000K - 90000lm - Ra 4

acc. 59 pole bracket	
galvanised	997900
Bracket for pole mounting 1 or 2 end-to-end floodlights. For $\phi$ 60/76 mm poles.	

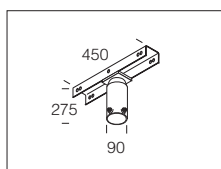

acc. 60 pole bracket	
galvanised	997901
Bracket for pole mounting 2 or 4 end-to-end exterior floodlights. For $\phi$ 60/76 mm poles.	

