

Diffuser: Anti-glare protective tube made of impact resistant, self-extinguishing, UV-stabilised, dustproof, anti-yellowing treated V2 clear polycarbonate, scored inside and smooth outside.

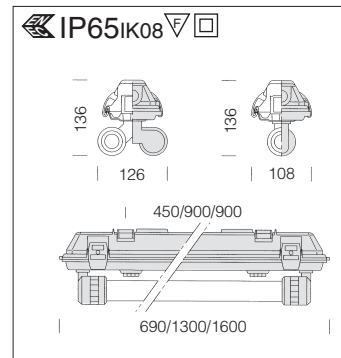

Housing: Injection moulded, vandal resistant, self-extinguishing, UV stabilised RAL 7035 grey polycarbonate, high mechanical resistance thanks to the stiffening ribs inside the structure.

		981 Lunar							
		CNR		CEL		CNR-E		CEL-D	
wattage	colour	weight	code	weight	code	weight	code	weight	code
FL 1x18	grey	1.50	166441-00	1.30	166441-08				
FL 1x36	grey	1.90	166442-00	1.70	166442-08	2.90	166442-07	1.80	166442-52
FL 1x58	grey	2.60	166443-00	2.40	166443-08	3.60	166443-07	2.50	166443-52
FL 2x18	grey	1.80	166444-00	1.60	166444-08				
FL 2x36	grey	2.90	166445-00	2.40	166445-08	3.90	166445-07	2.60	166445-52
FL 2x58	grey	3.80	166446-00	2.60	166446-08	4.80	166446-07	2.80	166446-52

On request: versions with 3 hour emergency duration.

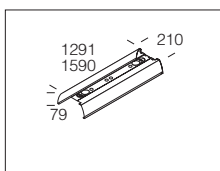
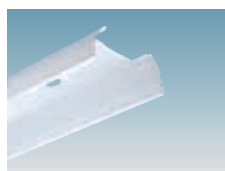

acc. 967 steel reflector

1/2x36	166554
1/2x58	166555

Cost-effectiveness, improved illuminance and light control. Steel painted white by UV-stabilised acrylic anionic electro-coating.

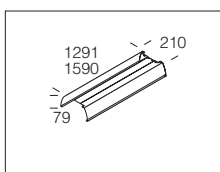
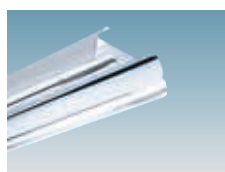
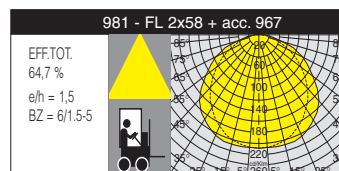

acc. 968 aluminium reflector

1/2x36	166556
1/2x58	166557

Better light control. Made of polished aluminium 99.85.

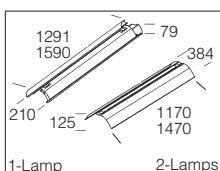
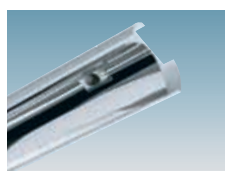
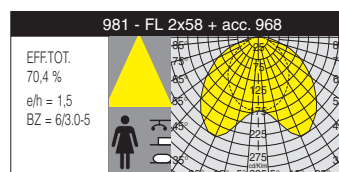

acc. 969 narrow beam reflector

1x36	166558
1x58	166559
2x36*	166560
2x58*	166561

Made of polished aluminium 99.85. *Two-lamp versions without reflector.

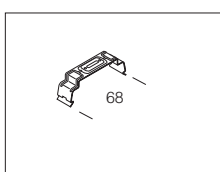
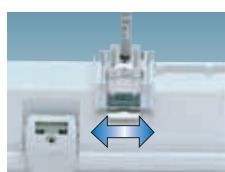
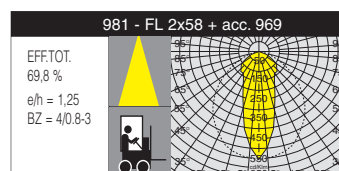

acc. 937 ceiling bracket

stainless s.	998072
--------------	--------

Made of stainless steel (AISI 304). Package holds 100 bags containing 2 brackets + 2 screws each. Price per pack.

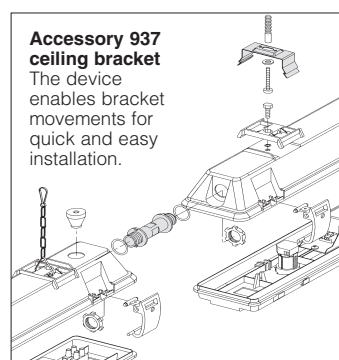

acc. 938 junction sleeve

	998073
--	--------

Made of polycarbonate, for junction and transit of power supply cables between lighting fixtures (max distance 30 linear m.). **2 per pack.**

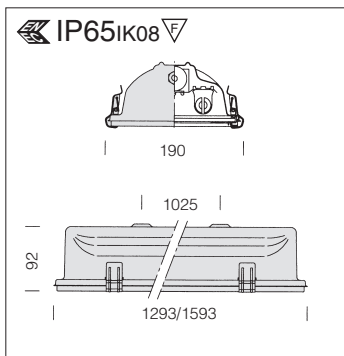

Housing: made of pressed steel, drawn in a single piece for high mechanical resistance. Supplied with frame.

Diffuser: impact-resistant tempered glass.

Reflector: Made of galvanised steel, pre-painted white and anti-yellowing treated.

Coating: polyester powder (art. 994) for better resistance to corrosion and saline environment.

Electric gear: 230V/50Hz power supply with $\Delta T55$ ballast. Hard wire, cross section 0.50 sqmm, and high-temperature resistant (up to 90°C) PVC-HT sheath, in accordance with CEI 20-20. 2P+T terminal block (maximum allowed lead cross-section: 2.5 sqmm).

Equipment: Fibreglass nylon cable gland, 1/2" gas thread. Fibreglass nylon or stainless steel locking hooks.

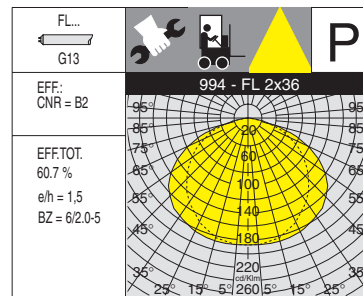

N.B. installation of fixtures providing indirect light with flat glass is not recommended for exterior application.



994 Forma - steel + glass							
		CNR		CNR-E		CEL	
wattage	colour	weight	code	weight	code	weight	code
FL 1x36	s. silver	7.50	162437-00	8.40	162437-07	7.30	162437-08
FL 1x58	s. silver	9.10	162438-00	10.00	162438-07	8.90	162438-08
FL 2x36	s. silver	8.20	162439-00	9.10	162439-07	8.00	162439-08
FL 2x58	s. silver	10.60	162440-00	11.50	162440-07	10.40	162440-08

On request: version complete with bracket, accessory 996 (use sub-code -0074 to order this item).
Other versions: with electronic dimmerable ballast (see chapter); ATEX versions (see chapter).

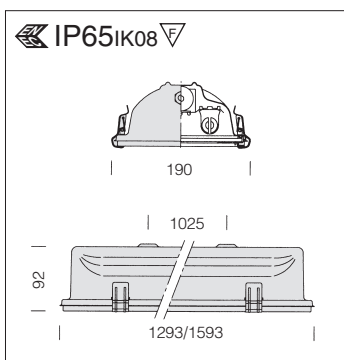

Housing: Made of AISI 304 18/8 stainless steel, drawn in a single, piece for high mechanical resistance. Supplied with frame.

On request: Version prepared for installation of access. 996 (use sub-code -0074 to order this accessory and purchase bracket access. 996).

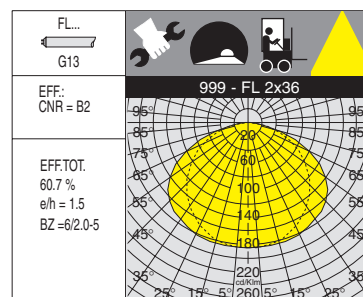

N.B. installation of fixtures providing indirect light with flat glass is not recommended for exterior application.



999 Forma - stainless steel + glass							
		CNR		CNR-E		CEL	
wattage	colour	weight	code	weight	code	weight	code
FL 1x36	natural	7.50	162461-00	8.40	162461-07	7.30	162461-08
FL 1x58	natural	9.10	162462-00	10.00	162462-07	8.90	162462-08
FL 2x36	natural	8.20	162463-00	9.60	162463-07	8.00	162463-08
FL 2x58	natural	10.60	162464-00	11.30	162464-07	10.40	162464-08

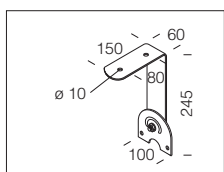

acc. 996 adjustable bracket	
stainless s.	166670
Made of stainless steel. For suspension and rotation. 2 per pack	

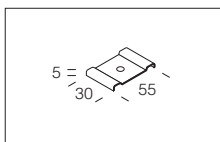

acc. 6036 universal connection	
galvanized	132987
Made of galvanized steel. To install non-corrosive fixtures on track art. 6000.	