

The electronic power supply unit provides approximately 22% energy saving compared with standard units, overvoltage resistance, short circuit protection, flicker-free ignition, no stroboscopic effect, noise-free operation.

Supplied with energy saving lamps.

924 Hydro - energy saving			
		CEL-F	
wattage	colour	weight	code
FLC 1x55L	grey	1.60	164590-00

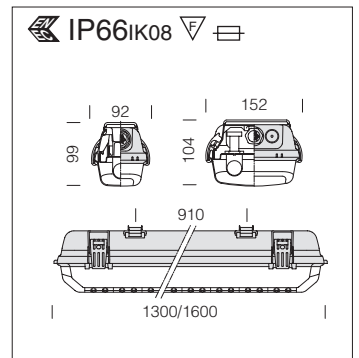
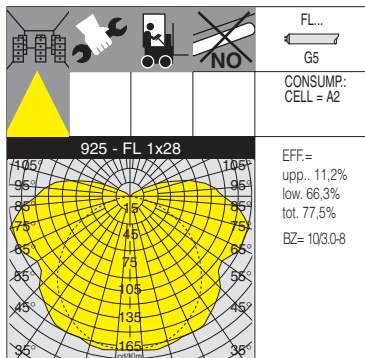

The electronic power supply unit provides approximately 22% energy saving compared with standard units, overvoltage resistance, short circuit protection, flicker-free ignition, no stroboscopic effect, noise-free operation.

On request: supplied with knife switch installed.
T5 versions are supplied with high luminous efficiency and energy saving lamps.

925 Hydro T5				
		CELL-F		Lamps (Ta=25°C)
wattage	colour	weight	code	Kelvin - ølm - Ra
FL 1x28	grey	2.20	164560-00	4000K - 2600lm - Ra 1b
FL 1x49	grey	2.90	164561-00	4000K - 4300lm - Ra 1b
FL 2x28	grey	3.00	164562-00	4000K - 2600lm - Ra 1b
FL 2x49	grey	3.80	164563-00	4000K - 4300lm - Ra 1b

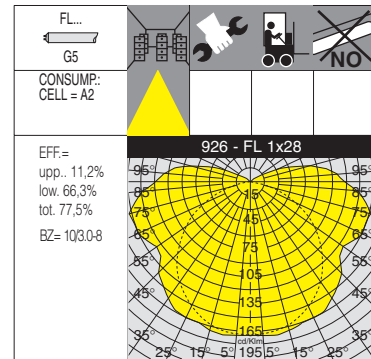
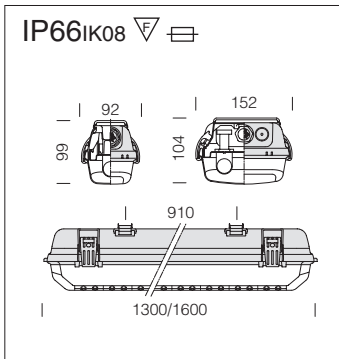

The electronic power supply unit provides approximately 22% energy saving compared with standard units, overvoltage resistance, short circuit protection, flicker-free ignition, no stroboscopic effect, noise-free operation. With a 60-minute run time emergency kit. In the event of a black-out the lamp connected to the back-up circuit stays on. When power is restored the battery recharges. On request: versions with 3 hour emergency duration.

On request: supplied with knife switch installed. T5 versions are supplied with high luminous efficiency and energy saving lamps.

926 Hydro T5 - electronic + emergency						
		CELL-E		CELL-E self-diagnosis		Lamps (Ta=25°C)
wattage	colour	weight	code	weight	code	Kelvin - olm - Ra
FL 1x28	grey	2.90	164570-00	2.90	164570-0066	4000K - 2600lm - Ra1b
FL 1x49	grey	3.60	164571-00	3.60	164571-0066	4000K - 4300lm - Ra1b
FL 2x28	grey	3.90	164572-00	3.90	164572-0066	4000K - 2600lm - Ra1b
FL 2x49	grey	4.40	164573-00	4.40	164573-0066	4000K - 4300lm - Ra1b

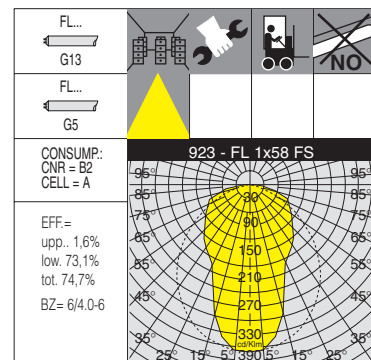
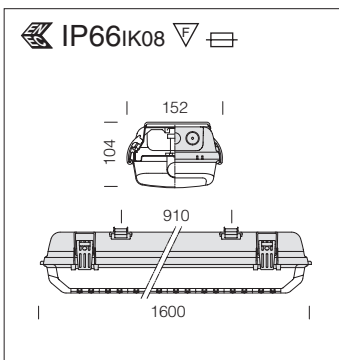

Recommended for premises over 4 metres high, or where INTENSIVE LIGHT is required.

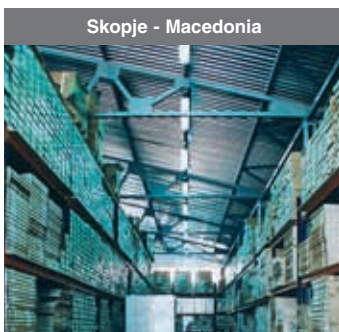

923 Hydro - narrow beam						
		T8 CNR-F		T5 CELL-F		Lamps (Ta=25°C)
wattage	colour	weight	code	weight	code	Kelvin - olm - Ra
FL 1x58	grey	3.70	164575-00			
FL 1x80	grey			3.70	164576-00	4000K - 6150lm - Ra1b