

Fixture housing: Galvanised steel previously stove-enamelled with UV-stabilised white polyester resin; rounded edges to prevent cutting; polycarbonate end caps.

Electric gear: 230V/50Hz power supply with ΔT 45 electronic ballast. Hard wire, cross section 0.50 sqmm, and high-temperature resistant (up to 90°C) PVC-HT sheath, in accordance with CEI 20-20 standards. 2P+T terminal block (maximum allowed lead cross section 2.5 sqmm.).

Standard supply: Nylon fastening pawl.

6401 Rapid system T8 - with knife switch							
		CNR		CEL		CNR-E	
wattage	colour	weight	code	weight	code	weight	code
FL 1x18	white	1.10	238040-00	0.90	238040-08		
FL 1x30	white	1.30	238041-00	1.10	238041-08		
FL 1x36	white	1.50	238042-00	1.40	237531-00	2.50	237551-00
FL 1x58	white	2.00	238043-00	1.80	237532-00	2.80	237552-00

Acc. 4605 for direct ceiling mounting. **Note: 6401EL: order the special version of acc 6405.**

6501 Rapid system T8 - with knife switch							
		CNR		CEL		CNR-E	
wattage	colour	weight	code	weight	code	weight	code
FL 2x18	white	1.15	238045-00	0.95	238045-08		
FL 2x36	white	2.05	238046-00	1.95	237536-00	3.00	238046-07
FL 2x58	white	2.95	238047-00	2.75	237537-00	4.00	237557-00

Acc. 4605 for direct ceiling mounting. **Note: 6401EL: order the special version of acc 6405.**

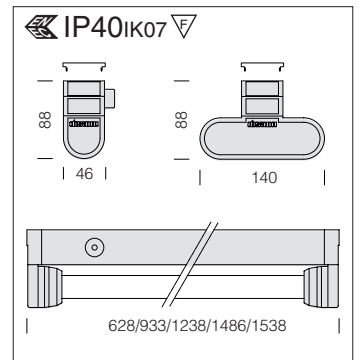
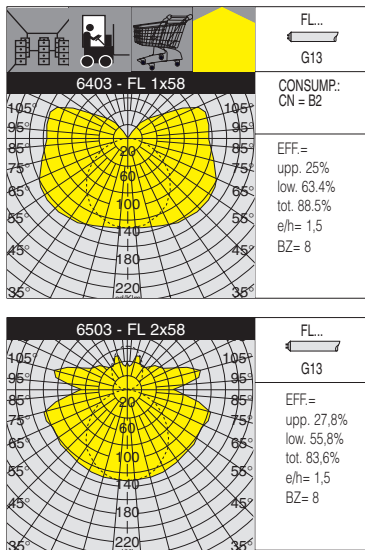

Fixture housing: Galvanised steel previously stove-enamelled with UV-stabilised white polyester resin; rounded edges to prevent cutting; polycarbonate end caps.

Electric gear: 230V/60Hz power supply with ΔT 45 electronic ballast. Hard wire, cross section 0.50 sqmm, and high-temperature resistant (up to 90°C) PVC-HT sheath, in accordance with CEI 20-20 standards. 2P+T terminal block (maximum allowed lead cross section 2.5 sqmm.).

Standard supply: Nylon fastening pawl.

Supplied with power terminal block and upper cover acc. 6405 for direct ceiling or wall mounting. For centralised power factor correction installations.

6403 Rapid system T8 - with upper cover							
		CN					
wattage	colour	weight	code				
FL 1x18	white	1.20	238120-00				
FL 1x30	white	1.50	238121-00				
FL 1x36	white	1.70	238122-00				
FL 1x58	white	2.10	238123-00				

6503 Rapid system T8 - with upper cover							
		CN					
wattage	colour	weight	code				
FL 2x18	white	1.25	238124-00				
FL 2x36	white	2.15	238125-00				
FL 2x58	white	3.05	238126-00				

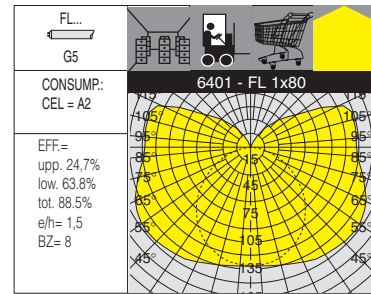
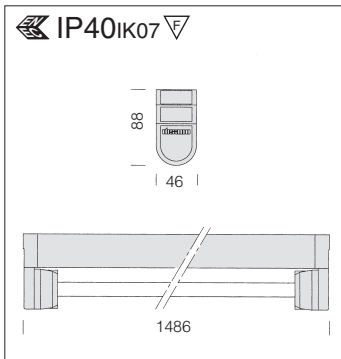

Fixture housing: Galvanised steel previously stove-enamelled with UV-stabilised white polyester resin; rounded edges to prevent cutting; polycarbonate end caps.

Electric gear: 230-240V/50-60Hz power supply with ΔT 55 electronic ballast. Hard wire, cross section 0.50 sqmm, and high-temperature resistant (up to 90°C) PVC-HT sheath, in accordance with CEI 20-20 standards. 2P+T terminal block (maximum allowed lead cross section 2.5 sqmm.).

Standard supply: Nylon fastening pawl.

6401 Rapid system T5 - with knife switch			
		CEL	
wattage	colour	weight	code
FL 1x80	white	2.90	238050-00
FL 1x49	white	2.90	238054-00

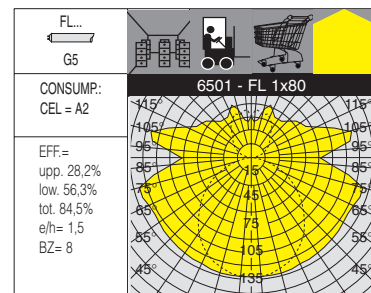
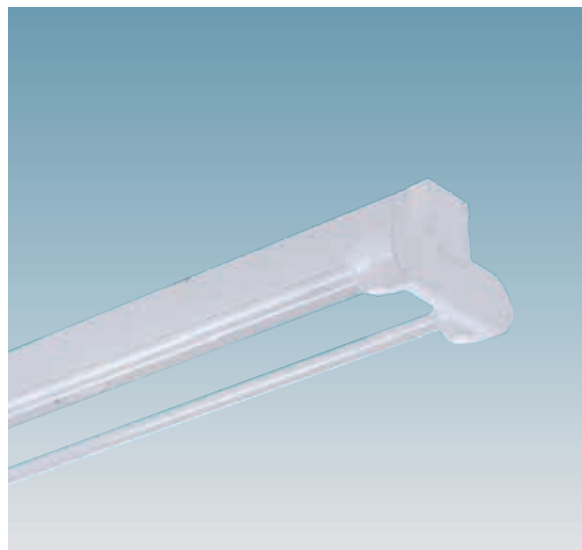
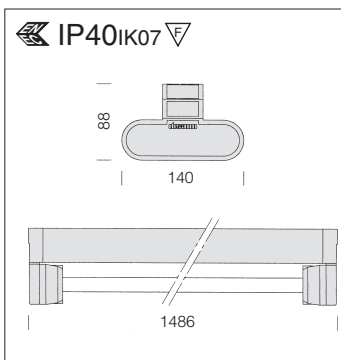

Fixture housing: Galvanised steel previously stove-enamelled with UV-stabilised white polyester resin; rounded edges to prevent cutting; polycarbonate end caps.

Electric gear: 230-240V/50-60Hz power supply with ΔT 55 electronic ballast. Hard wire, cross section 0.50 sqmm, and high-temperature resistant (up to 90°C) PVC-HT sheath, in accordance with CEI 20-20 standards. 2P+T terminal block (maximum allowed lead cross section 2.5 sqmm.).

Standard supply: Nylon fastening pawl.

6501 Rapid system T5 - with knife switch			
		CEL	
wattage	colour	weight	code
FL 2x80	white	2.90	238051-00
FL 2x49	white	2.90	238055-00

acc. 79 knife switch	
985005	
For quick connection to the power line and for automatic power line cutoff during maintenance. To be used with acc 6030.	

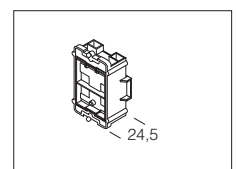
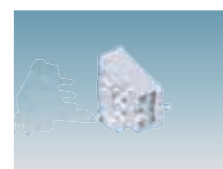

● = application examples

acc. 6412 one/two-lamp reflector	
1/2x80	237744
Diffusing. Polished high gloss aluminium 99.85, anodized 2μ.	

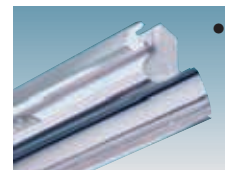
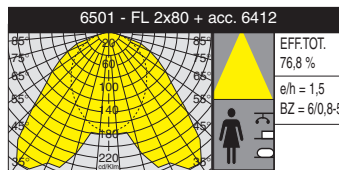
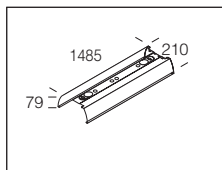
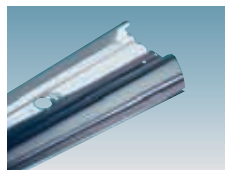

acc. 6413 single narrow beam refl.	
1x80	237736
Polished high-gloss aluminium 99.85, anodised 2μ.	
Applications: warehouses with high narrow corridors.	

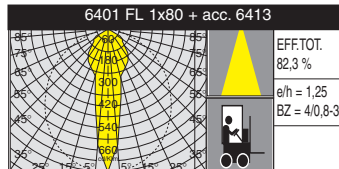
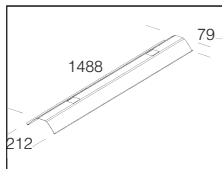
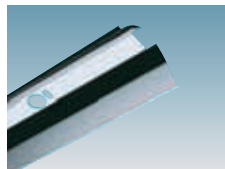

acc. 6414 concave reflector	
2x80	237739
Polished high-gloss aluminium 99.85, anodised 2μ.	
Applications: warehouses with high narrow corridors.	

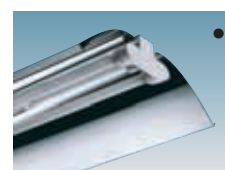
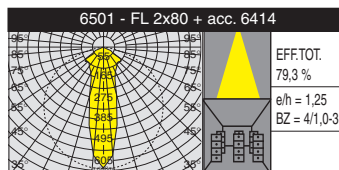
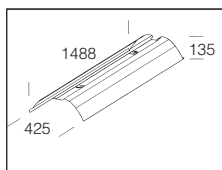
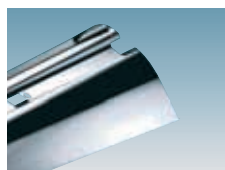

acc. 6416 one/two-lamp diffuser	
1/2x18	237741
1/2x36	237742
1/2x58	237743
1/2x80	237747
Made of steel, pre-painted white with polyester resin.	

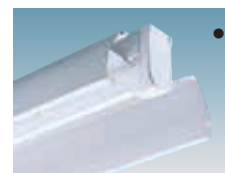
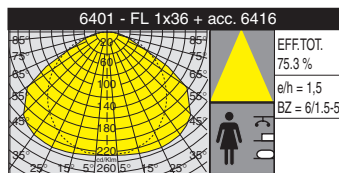
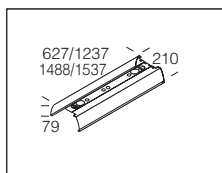
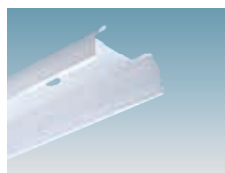

acc. 6440 one-lamp corner refl.	
1x18	237715
1x36	237716
1x58	237717
Made of steel, pre-painted white with polyester resin.	
Applications: working benches.	

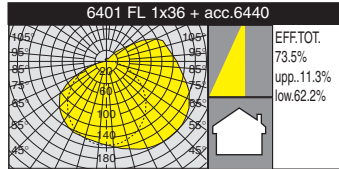
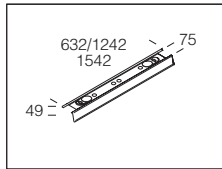

acc. 6417 dir/ind. light reflector	
1/2x36	237745
1/2x58	237746
Made of steel. The fixture provides direct and indirect light with upper slots for indirect output.	

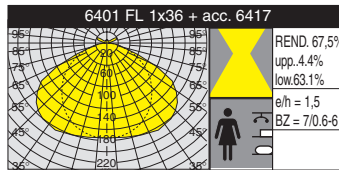
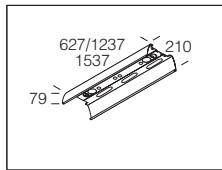
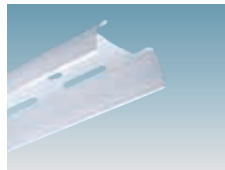

acc. 6413 single narrow beam refl.	
1x36	237734
1x58	237735
Polished high-gloss aluminium 99.85, anodised 2μ.	
Applications: warehouses with high narrow corridors.	

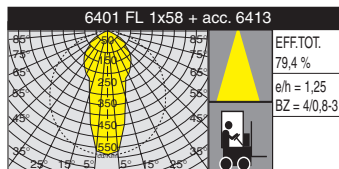
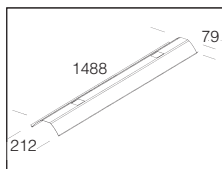
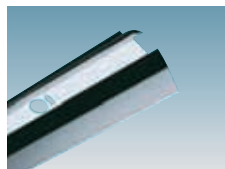

acc. 6424 one/two-lamp louvre	
white	237759
metal.	237760
Made of polycarbonate. For better light control and to reduce glare.	

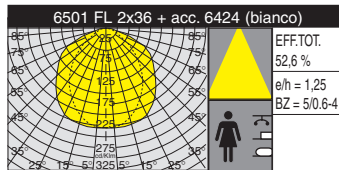
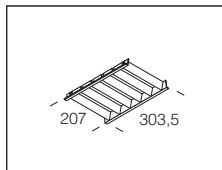
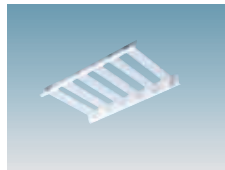

acc. 6405 upper cover	
18	237603
30	237602
36	237604
58	237605
1/2x80	237612
White steel. For ceiling mounting.	

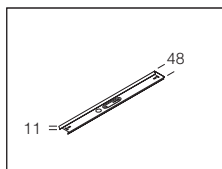
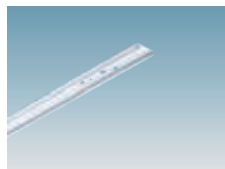

acc. 6422 alignment joint	
white	237756
Made of ABS. To align accessories 6416/6417/6418 installed in a continuous line. 2 per pack.	

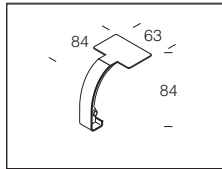

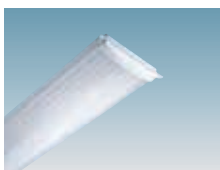
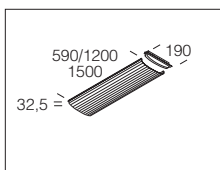
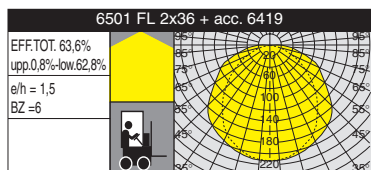

acc. 6419 one/two-lamp diffuser	
1/2x18	237750
1/2x36	237751
1/2x58	237752
Plexiglass, fluted inside and smooth outside, to be applied on reflector acc 6416/6417.	

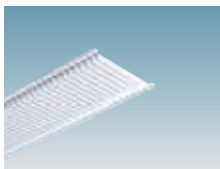
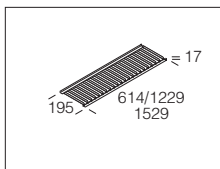
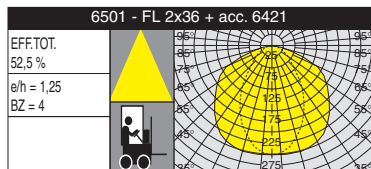

acc. 6421 one/two-lamp louvre	
1/2x18	237753
1/2x36	237754
1/2x58	237755
Made of sheet steel, painted white. To be applied to art.6416/6417.	

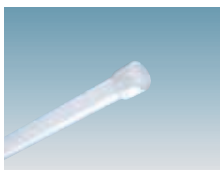
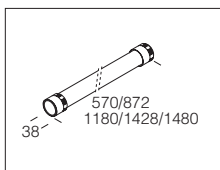
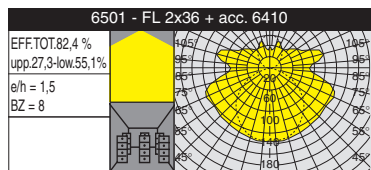

acc. 6410 protection tube	
1/2x18	237606
1x30	237601
1/2x36	237607
1/2x58	237608
1/2x80	237615
V2 polycarbonate. Scored inside; smooth, dustproof outside.	

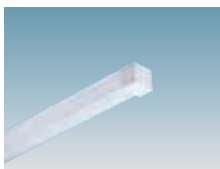
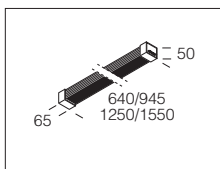
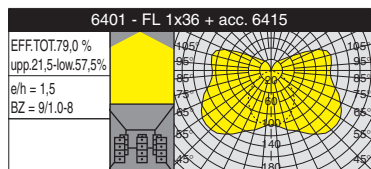

acc. 6415 one-lamp diffuser	
1x18	237609
1x30	237600
1x36	237610
1x58	237611
Plexiglass, fluted inside.	

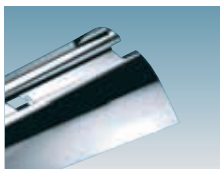
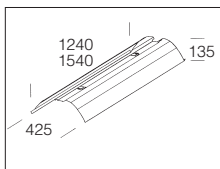
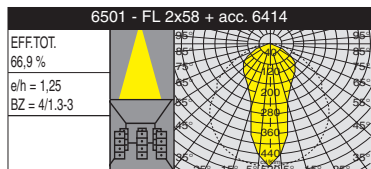

acc. 6414 concave reflector	
2x36	237737
2x58	237738
Polished high-gloss aluminium 99.85, anodised 2µ.	

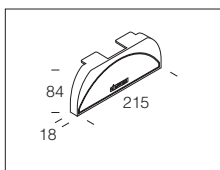

acc. 6423 end cap	
white	237757
Made of ABS. To be used as end cap for stand-alone or end reflectors of a continuous line. 2 per pack.	

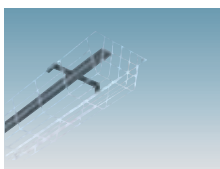
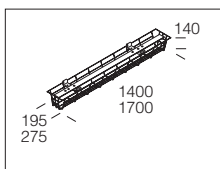

acc. 975 impact protection guard	
1x36	165564
1x58	165565
2x36	165566
2x58	165567
White plastic-coated steel rod. To be installed directly on the ceiling.	

● = application examples

